



a division of  
**SOLARBOTICS**

# PIR Sensor

Passive Infrared  
Motion Detector



Ideal for home automation projects

- 5V Output Signal
- Only 3 Connections - Power, Ground, and Signal
- Mounted Fresnel Lens
- Easy to use

Thank you for purchasing the Passive InfraRed (PIR) Motion Detector. This sensor is easily used in any electronic design. Only three connections are required, Power, Ground and Signal. The sensor system includes a Fresnel lens, a pyroelectric sensor, and a controller IC all mounted on a 25mm x 35mm printed circuit board.

## Using the PIR Motion Detector

After you connect the detector to power and ground it takes approximately one minute for the sensor to fully stabilize. When the sensor detects an object it will give a positive pulse for approximately 1 second.

The quickest and easiest way to try the PIR is by connecting an LED and a current limiting resistor to the sensor.

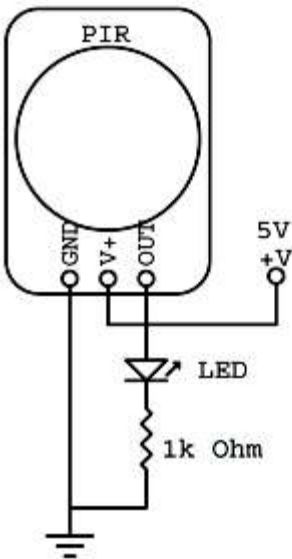

Figure 1.1:  
Quick Test

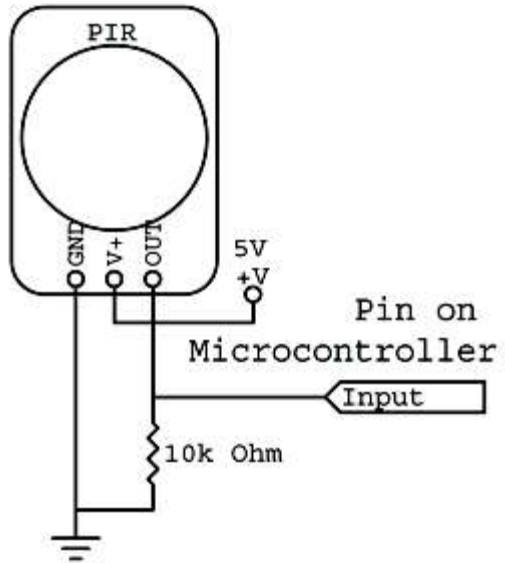

Figure 1.2:  
Attaching to Microcontroller

## Background Information

The pyroelectric sensor combines a crystal and a filter to produce an electric charge when exposed to infrared radiation. Some ferroelectric materials will spontaneously develop a charge when the temperature of the material is changed. Any change in the incident radiation can change the temperature of a crystal material. This type of material is affected by a wide range of radiation. The filter is used to select a range of radiation

that is associated with the human body's natural radiation. There are two sensing regions on the device. This arrangement cancels signals caused by the ambient conditions like sunlight or room temperature. A body passing in front of the sensor will activate first one and then the other element whereas other sources will affect both elements simultaneously.

The module uses an IC and various components to control the sensor. The IC cancels any noise and sets the timing for the output signal. The voltage applied to the sensor is controlled by various components on the PCB. All you need to provide is +5V and Ground.

## Specifications

Operating Voltage	5 VDC
Standby Current	350µA
Output Signal	TTL High Level
Dimension	25 x 35 x 18 mm
Lens	Ball Lens
Detection Angle	60°
Detection Distance	5m

## Technical Support

Symptom	Probable Cause / Solution
LED doesn't light at all	-No power. Connect + Volts -Resistor (#2 in Figure 1) is missing. Install resistor.
LED stays on too long	-This is a configuration set by the IC

Technical support is available if you are having problems. If you need help, please provide as much detailed information as possible.

E-mail: [support@hvwtech.com](mailto:support@hvwtech.com)

Phone: (403) 730-8603 (Monday - Friday 9am – 5pm Mountain time)

## Human Body Detection Made Easy

- Simple 5V Connection
- Easily Connects to any Microcontroller
- Build your own Alarm System
- Great for Home Automation

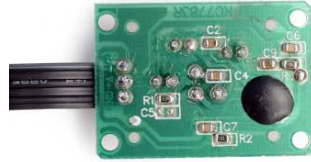

### Other products from HVW Technologies:



**Stamp Stack II:** The ultimate BASIC Stamp II prototyping tool. A complete BASIC Stamp II on a board that mounts onto a solderless breadboard. Includes a serial connector, reset switch and a "bullet-proof" power supply. Easy to build, simple to use.

#### Plus...

- Microcontrollers
- IR Sensors
- Compilers
- PIC Programmers
- Proto Boards
- FPGA Development Kits
- Robotics Kits/Part
- Instructional Books
- Gifts & Toys
- Tools and test equipment

Visit us online for more info and neat things:

[www.HVWTech.com](http://www.HVWTech.com)

HVW Technologies Inc.  
201 35th Ave NE  
Calgary, Alberta T2E 2K5  
Canada



**Toll Free:** 1-888-448-9832

**International:** +1 (403) 730-8603



**Fax:** +1 (403) 730-8903

HVW Technologies Inc. is a division of Solarbotics Ltd.  
visit us online at [www.solarbotics.com](http://www.solarbotics.com)



Packaged in Canada